

CG400/450

Submittal Data Information

Probe Type Low Water Cut-Off - Foam Compensating Residential Steam Boilers

CycleGard™

Supersedes: July 1, 2010

Effective: Feb 1, 2011

JOB _____ ENGINEER _____ CONTRACTOR _____

Item Number	Model Number	Notes

Features

- **Low Maintenance** - No moving parts to stick or hang up as in float type devices.
- **Advanced Micro Processor Design**
For the highest level of performance and reliability.
- **Intermittent Level Test** - Periodically monitors settled water level for added protection for today's smaller, more efficient steam boilers.
- **Smart-Cycle** - Direct connection to the burner allows the CycleGard to monitor boiler firing, so the control initiates a test sequence only when the burner fires.
- **Variety of Time Sequences Available**
Assures proper control for the boiler and the installation.

Standard Application

CycleGard Low Water Cut-Offs are used as the primary low water cut-off on residential and light commercial steam heating boilers. They are also used in certain low pressure steam process applications

Operation

Hydrolevel controls utilize a non-moving, heavy duty, electronic probe to sense liquid levels. The probe can be installed in an equalizing line or directly into a boiler or tank. When water is in contact with the probe, it completes a circuit between the stainless steel probe tip and the tank or boiler surface in which the probe is installed. When the water level drops below the probe, the circuit opens.

Hydrolevel low water cut-offs for hydronic or steam systems use the water signal to allow the burner to operate. If the water level drops below the probe, the circuit opens and the control shuts of the burner. Hydrolevel controls for steam boilers utilize both on-time and off-time delays to prevent boiler short cycling and to facilitate proper boiler automatic water feeding.

The CycleGard Principle

To provide added protection for today's small, more efficient steam boilers, the CycleGard low water cut-off is equipped with an Intermittent Level Test (ILT) feature. This important feature adds an extra level of protection against false signals that can be caused by foam and volatile water conditions inside the boiler. The ILT removes power to the burner at preset intervals. During the test, foam dissipates and the water level stabilizes - allowing the CycleGard to monitor the true water level in the boiler, assuring safe and accurate operation.

Specifications

- **Switch Contacts**.....SPDT
- **Maximum Ambient Temperature**.....100°F
- **Input Voltage:** (CG400 Series)....24VAC/60HZ
(CG450 Series)...120VAC/60HZ
- **Power Consumption**.....3.6 VA
- **Max Steam Boiler Pressure**.....15 psi
- **Switch Contact Ratings**.....5.8 FLA
34.8 LRA
- **Alarm Circuit**.....50VA@24VAC Pilot Duty
or 125VA@120VAC Pilot Duty
- **Agency Listing**.....U.L.353
- **NEMA Classification**.....NEMA 1

Dimensions

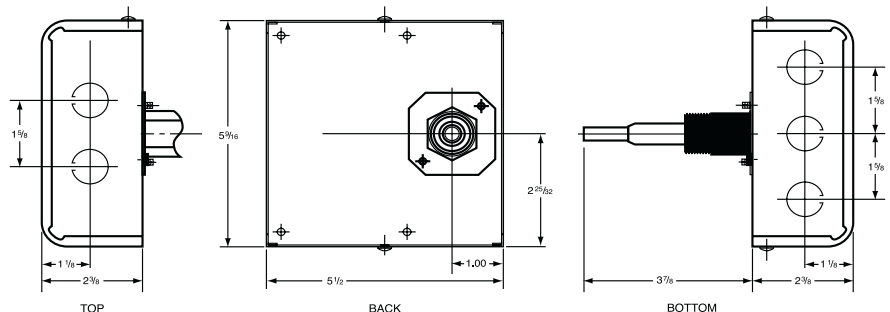

MATERIALS OF CONSTRUCTION	
Control Chassis	Galvanized Steel
Control Cover	Powder Coated Steel
Probe Insulator	Glazed Ceramic
Probe Tip	316 Stainless Steel
Probe Nut	3/4" or 1/2" NPT Brass

MODEL SUFFIX REFERENCE TABLE		
Models Ending In:	Run Time	Test Time
1090	10 Min.	90 Sec.
1560	15 Min.	60 Sec.
2060	20 Min.	60 Sec.
2090	20 Min.	90 Sec.

**HYDROLEVEL
COMPANY**

83 Water Street, New Haven, CT 06511
(800) 654-0768
www.hydrolevel.com